

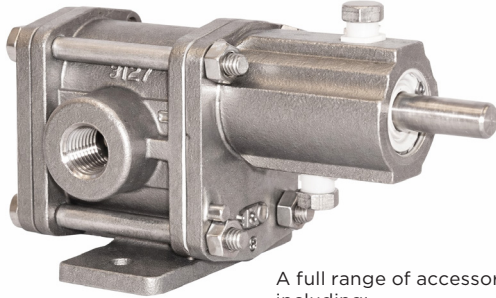

# OBERDORFER®

An Ingersoll Rand Business

## R104 METALLIC CHEMSTEEL SERIES



- A full range of accessories are available including:
- close coupled mounting kits
  - baseplate/pedestal mounting kits
  - line mounted pressure relief valves

### General Description

Chemsteel pumps are designed to handle common and highly corrosive liquids that must be pumped under pressure. Manufactured to extremely precise tolerance, the Chemsteel pump line prevents system contamination while maintaining the purity and integrity of the liquid being pumped. Its rugged, three-section, o-ring sealed thru-bolt construction provides ease of servicing and parts replacement. Helical gearing offers noise reduction by as much as 10db, while the tandem pumps double the output flow for a single fluid, or with isolation, handle other fluids in direct ratio to the first. Additionally, Chemsteel pumps offer bi-directional operation for applications requiring reversing flow.

### Fit

Connections are 1/2" female NPT or BSPT, pump hardware is metric and close couple adapters mount to both NEMA and IEC standard motor frame sizes for world wide acceptance. "Near" dimensional interchangeability offers easy upgrade to Chemsteel pump. The port size is the same as competitive pumps.

### Specific Solutions

Gear/bearing design allows for "trimming" for optimizing the pump's maximum flow to reach minimum turndown or to match flow to a specific OEM's requirement. Special materials combinations are available for specific liquids:

- 316 stainless or Alloy C housing construction.
- Gears available in 316 stainless, Alloy C. Also in PTFE White and Polyetheretherketone.
- Shafts are 316 stainless steel or Alloy C.
- Bearings available in Carbon or PTFE.

### Performance

Capacity water at 70°F / 21°C

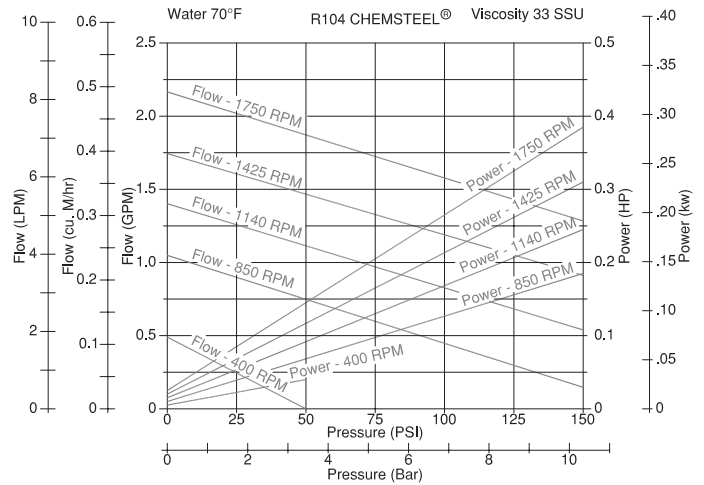

Notes: For continuous service:  
 Plastic / Plastic gear combinations are limited to 50 psi or 3.5 bar.  
 Metal / Plastic gear combinations are limited to 100 psi or 7 bar.  
 Metal/Metal gear combinations are limited to 150 psi or 10.3 bar.  
 Horsepower requirements increase for viscous fluids.

### Specific Solutions

Pump design and materials selection, together provide the longest life available from a gear pump.

Key attributes include:

- Gear & bearing combinations of metallic and nonmetallic wear surfaces.
- Slotted bearings to lubricate shaft and gear surfaces.
- Hydraulic porting to balance axial thrust and to reduce wear.
- Ample port sizing to reduce the likelihood of cavitation when inlet pressure is marginal.
- Effective housing seals with elastic memory prevent leakage of corrosives.

MODEL	R104	
MAXIMUM FLOW (GPM/LPM) @1750 RPM	2 GPM	7.6 LPM (0.45 m <sup>3</sup> /h)
THEORETICAL DISPLACEMENT	5.7 CC/REVOLUTION	
MAXIMUM DIFFERENTIAL PRESSURE	150 PSIG	10.3 BAR
MAXIMUM SYSTEM PRESSURE	300 PSIG	20.7 BAR
MAXIMUM SPEED	1800 RPM	
MAXIMUM FLUID TEMPERATURE	450° F	232° C
MINIMUM FLUID TEMPERATURE	-50° F	-46° C
STANDARD PORT SIZE	1/2" FNPT	1/2" BSPT
WEIGHT-LESS MOTOR	4 LBS	1.8 KG



**OBERDORFER**<sup>®</sup>

An Ingersoll Rand Business

## Maintenance

A three-part housing provides easy disassembly and service. Full size bearings match the gear diameter, and eliminate the need for separate wear plates. TFE encapsulating silicone o-ring pump housing seals provide elastic memory to assure an effective long lasting seal and thus avoiding the re-torquing required of pumps using pure TFE. The upper shaft configuration lends itself to in-line pump seal maintenance without the leakage of trapped chemicals from an incompletely drained pump.

To order a CHEMkit<sup>®</sup>, simply add a "K" to the end of the model number. A repair kit contains the following parts: bearings, gears, o-rings, shafts, keys, c clips, and retaining ring.

## Close-Coupled Dimensions

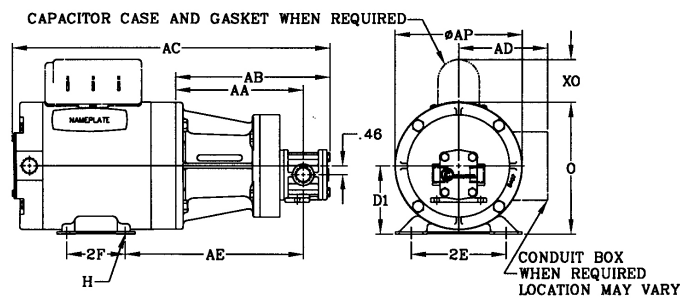

## Pedestal Mount Dimensions

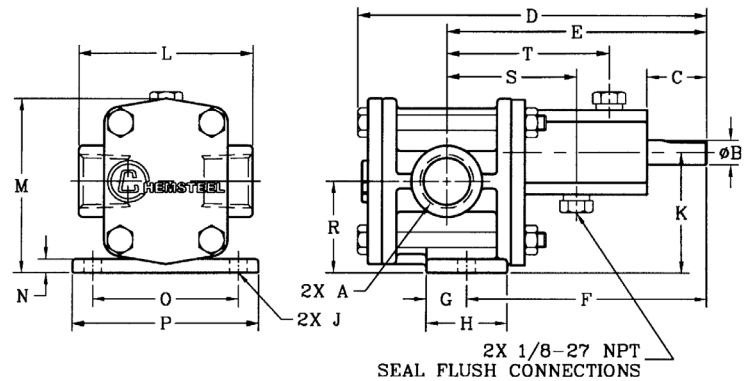

## Close-Coupled Dimensions

MOUNTED ADAPTER CODE	KIT PART NO.	MOTOR FRAME		D1	2E	2F	H	O*	AP*	XO*	AA	AB	AC	AD*	AE
C1	M1AD56	56C	INCHES	3.50	4.88	3.00	.34 SLOT	6.88	6.63	2.25	6.54	7.92	16.30	-	9.11
			MILIMETERS	88.9	124	76.2	8.6 SLOT	174.8	168.4	57.2	166.1	201.2	414.0	-	231.4
C2	M1AD45T	143TC   145TC	INCHES	3.50	5.50	4.00   5.00	.34 SLOT	6.88	6.63	2.25	6.54	7.92	17.49   18.99	4.57	8.93
			MILIMETERS	88.9	139.7	102   127	8.6 SLOT	174.8	168.4	57.2	166.1	201.2	444.2   482.3	116.1	226.8
C3	M1AD71E	IEC 71, B14 FACE	INCHES	2.80	4.41	3.54	.28 SLOT	5.14	4.69	-	6.05	7.43	16.74	4.00	7.82
			MILIMETERS	71	112	89.9	7 SLOT	130.6	119.1	-	153.7	188.7	425.2	102	198.6
C4	M1AD80E	IEC 80, B14 FACE	INCHES	3.15	4.92	3.94	.39 SLOT	6.00	5.69	-	6.05	7.43	16.97	4.51	8.02
			MILIMETERS	80	125	100.1	10 SLOT	152.4	144.5	-	153.7	188.7	4.31	116	203.7

\* These dimensions vary depending on HP, enclosure, speed and motor manufacturer.

## Pedestal Mount Dimensions

	A	B	C			D	E	F	G	H	J	K		L	M	N	O	P	R
			Mechanical	Pack <sup>2</sup>	Lip						Diameter	Standard Drive	Lower Drive						
INCH.	0.50	0.50	1.28	0.72	1.26	6.28	4.60	4.22	0.56	1.38	0.34	2.63	1.33	2.63	3.75	0.25	2.25	3.00	1.97
MM	12.7	12.7	32.5	18.2	32.0	159.5	116.8	107.2	14.2	35.1	8.6	66.7	33.7	66.8	95.3	6.4	57.2	76.2	50.0

Notes: Dimension is approximated with packing nut installed



12500 South Pulaski Road  
Alsip, IL 60803, USA  
Phone (800) 448.1668